



Sparex

Your 1st choice

S.166336



IP69K



Wired



Max 4 cameras



7" HD

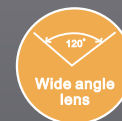

Wide angle lens



+70°C
-20°C
Operating temperature



HD Digital Wired System User Manual

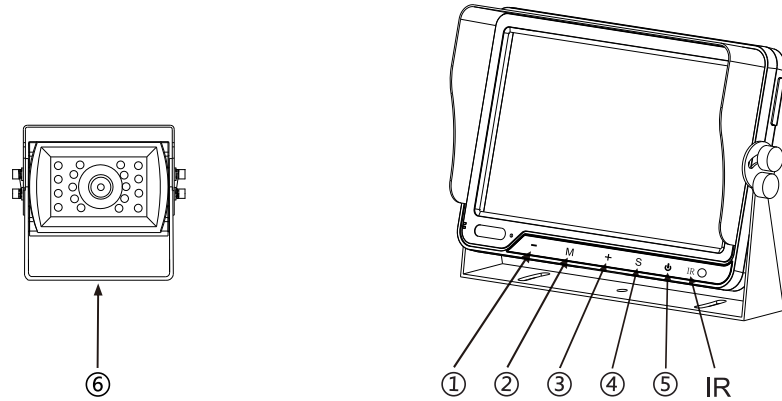

- ① Left(Vol-)
- ② Menu/Move down
- ③ Right(Vol+)
- ④ Channel selection
- ⑤ Power
- ⑥ Camera

Power Connection

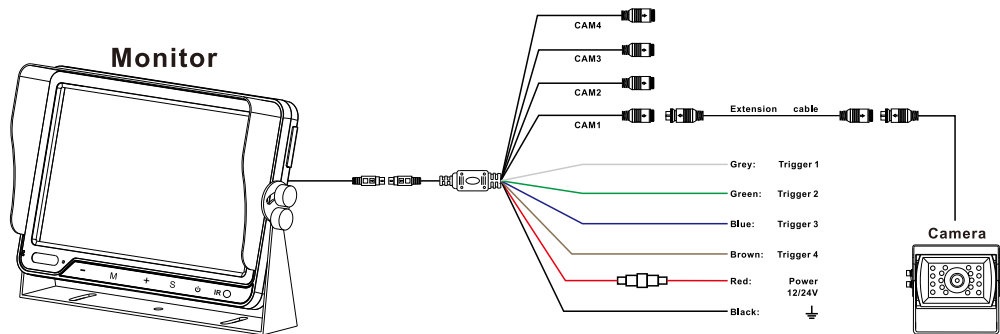

Declaration of Conformity

Name of supplier: Sparex Group
 Manufacturer: Guangzhou Besyo Auto Parts CO.,LTD
 Supplier of address: Exeter Airport, Devon EX5 2LJ, United Kingdom
 Manufacturer: 1208, The 12th Floor, Xiangyun Building, NO.1400 Baiyun Avenue, Baiyun District, Guangzhou,P.R.C

CE Declaration of Conformity compliance with the council EMC Directive 2014/30/EU.

RoHS Declaration of Conformity compliance with the council RoHS directive 2011/65/EU its amendment Directive EU 2015/863

E9 Declaration of Conformity concern of a type of electronic sub-assembly with regard to ECE Regulation No. 10.05.

UK CA Declaration of Conformity in accordance with Regulation 43 of the Electromagnetic Compatibility Regulations 2016 (SI 2016 No. 1091, as amended).

With amendment of the EC Directives and Standards, this declaration is valid for each unit of this article which is delivered to Sparex Ltd

Article Name: Monitor with camera
 Supplier's Article No.: BY-08677M, BY-02063
 Sparex Article No.: S.166336

Implemented harmonized, Standard according to	CE(EMC) <u>EN 50498:2010</u>	RoHS <u>IEC62321-1:2013</u>	E9 <u>ECE No. 10.05</u>	UKCA <u>EN 55032:2015+A11:2020</u> <u>EN 55035:2017</u>
---	--	---------------------------------------	-----------------------------------	--

Official Agency:	<u>Shenzhen DL Testing Technology Co., Ltd</u> <u>DL-20210419017C</u>	<u>Shenzhen DL Testing Technology Co., Ltd</u> <u>DL-2019061761C</u>	<u>IDIADA Automotive Technology, S.A.</u> <u>E9-10R-05.16059</u> <u>E9*10R05/01*16583*00</u> <u>Jan. 18, 2018 Feb.20,2019</u>	<u>Element Materials Technology Warwick Ltd</u> <u>EMA21UKEMC0006</u> <u>EMA21UKEMC0002</u> <u>Mar.22,2021 Feb.02,2021</u>
------------------	--	---	--	---

Certificate No.:	<u>DL-20210419016C</u>	<u>DL-2019061761C</u>	<u>E9*10R05/01*16583*00</u> <u>Jan. 18, 2018 Feb.20,2019</u>	<u>Mar.22,2021 Feb.02,2021</u>
------------------	------------------------	-----------------------	---	--------------------------------

Date of Issue:	<u>Apr. 20, 2021</u>	<u>Jun. 10, 2019</u>	<u>Jan. 18, 2018 Feb.20,2019</u>	<u>Mar.22,2021 Feb.02,2021</u>
----------------	----------------------	----------------------	----------------------------------	--------------------------------

Signature with Company Chop:				
------------------------------	--	--	--	--

Typed name/title of authorized person	<u>Jade Yang</u> <u>/Manager</u>	<u>Jade Yang</u> <u>/Manager</u>	<u>Kent Lian/Auditor</u> <u>Lluís Sana Gomis</u> <u>/Department Manager</u>	<u>Josh Batty/Deputy Certification Manager</u>
---------------------------------------	-------------------------------------	-------------------------------------	---	--

Designed & Importer by:	Manufactured by:
Sparex Group Exeter Airport Devon EX5 2LJ United Kingdom	Guangzhou Besyo Auto Parts CO., LTD 1208, The 12th Floor, Xiangyun Building, NO.1400 Baiyun Avenue, Baiyun District,Guangzhou. People Republic of China
Sparex France Z.A.E de Ty douar 29450 Commana France	



Warning

- GB** The system maintenance must be maintained by professionals, please do not open and improve the system! The system is only for the safe operation of equipment and not responsible for accidents! This manual is for reference only. If unknown, or any changes, we will give no notice. The final interpretation right belongs to the manufacturer.
- ES** El mantenimiento del sistema debe ser realizado por profesionales. No intente abrir ni mejorar el sistema. El sistema es solo para el funcionamiento seguro del equipo y no es responsable de accidentes. Este manual es solo para referencia. No lo notificaremos de cambios o aspectos desconocidos. El derecho de la interpretación final le pertenece al fabricante.
- NL** Het systeem onderhoud moet worden onderhouden door professionals, gelieve niet te openen en het systeem te verbeteren! Het systeem is alleen voor de veilige werking van de apparatuur en niet verantwoordelijk voor ongelukken! Deze handleiding is alleen ter referentie. Indien er onbekende dingen gebeuren, of wijzigingen zijn, zullen wij u niet contacteren. Het uiteindelijke oordeel berust bij de fabrikant.
- FR** L'entretien du système doit être effectué par des professionnels, veuillez ne pas ouvrir et améliorer le système ! Le système est seulement destiné au fonctionnement sûr de l'équipement et ne peut être tenu responsable des accidents ! Ce manuel est seulement à titre de référence. En cas d'inconnu, ou de tout changement, nous ne donnerons aucun préavis. Le droit d'interprétation final appartient au fabricant.
- DE** Die Systemwartung muss von Fachleuten durchgeführt werden, bitte das System nicht selbstständig öffnen und keine Verbesserungsversuche vornehmen! Das System dient nur für den sicheren Betrieb von Geräten und wir übernehmen keine Haftung für jegliche Unfälle! Dieses Handbuch dient nur als Referenz. Wir behalten uns das Recht auf jegliche Änderungen ohne Ankündigung vor. Das Recht auf die endgültige Auslegung liegt beim Hersteller.
- DK** Systemvedligeholdelse skal vedligeholdes af fagfolk. Du må ikke åbne og forsøge at forbedre systemet! Systemet er kun beregnet til sikker betjening af udstyret og er ikke ansvarligt for ulykker! Denne vejledning er kun til reference. Hvis det er ukendt eller der er ændringer, giver vi ingen besked. Den endelige fortolkningsret tilhører producenten.
- PL** Konserwację systemu mogą przeprowadzać wyłącznie specjaliści, nie wolno otwierać ani ingerować w system! System służy do bezpiecznej obsługi urządzeń, jednak nie gwarantuje braku wypadków! Niniejsza instrukcja ma znaczenie tylko informacyjne. Nie powiadamy o wprowadzanych zmianach. Prawo do ostatecznej interpretacji należy do producenta.
- IT** La manutenzione del sistema deve essere effettuata da professionisti, si prega di non aprire ed apportare miglioramenti al sistema! Il sistema è progettato per garantire il funzionamento sicuro delle attrezzature e non è responsabile di eventuali incidenti! Questo manuale è solo per riferimento. Per novità, o eventuali modifiche, non daremo alcun preavviso. Il diritto di interpretazione finale appartiene al produttore.
- PT** A manutenção do sistema deve ser realizada por profissionais. Não abra nem modifique o sistema! O sistema destina-se unicamente à operação segura do equipamento e não é responsável por acidentes! Este manual serve unicamente para referência. Se desconhecido ou quaisquer alterações, não enviaremos nenhum aviso. O direito de interpretação final pertence ao fabricante.

Contact Information

Europe Austria Tel: +43 4212 6000 Sparex Austria Mauerbachg. 10 Hummendorf 9300	Belgium / Lux Tel: +32 54295 310 Sparex Belgium/Belga Industrieweg 2 B-8820 Waasland	Denmark Tel: +45 647 22287 Sparex Denmark Sparex Limited ApS Hvidevej 1 8600 Sønder	Italy Tel: +39 0432 6000 Sparex Austria Mauerbachg. 10 Hummendorf 9300	Netherlands Tel: +31 235 841 020 Sparex Holland BV Loozenweg 100 2155 GM Nieuw-Wenep	Poland Tel: +48 61 816 1937 61-108 ul. Rolaj 164, Poznań
France Tel: +33 2987 80234 Sparex S.A. R.L. Zeehoofdweg Commana 28450	Germany Tel: +49 4318 93100 Sparex Germany Haverstrang 2 Sittensen 27459	Ireland Tel: +353 31 805082 Sparex (Tractor Accessories Ltd) Haverstrang 2 Waterford Ireland	Portugal Tel: +351 261 311 107 Sparex Portugal, importação e Comércio Peças Lda Lugar da Espera 2565-716-Runa	Spain Tel: +34 911 33924 Sparex Agriproyectos, S.L./C/ Jose Maria (Sarratzena) Nr. 15 B 05006 Victoria-Garceta (Alava)	UK Tel: +44 1392 441338 Sparex Limited Eastern Business Devon Exeter EX4 2LJ
North America Canada Tel: +1 905 784 727 Sparex Canada Highway No 20 in Newcastle L1B 1P9	USA Tel: +1 330 629 1150 Sparex US PO Box 530 Aurora, OH 44202	Africa South Africa Tel: +27 21 881 9752 Sparex US Cape Town 35 George Blake St Flamingobush Stellenbosch 7600	Australasia Australia Tel: +61 298 200 752 Sparex Australia Pty Ltd 85-87 Strathairn Avenue Sunshine West, VIC 3020	New Zealand Tel: +64 6338 4122 4 Princes Street Dunedin Auckland 1145	Sparex Export Markets Espart Tel: +43 330 441334 Sparex Limited Eastern Business Devon Exeter EX4 2LJ

Feature

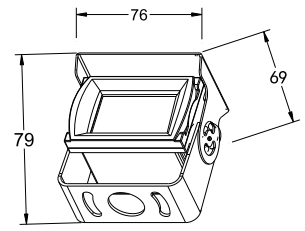

Camera	
	120°
	IP69K
	Yes
	-20°C ~ 70°C -68°F ~ 158°F
	10m
	10G
	12V

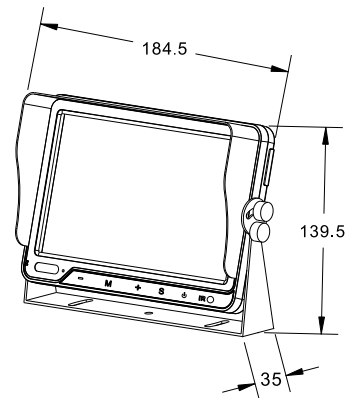

Monitor	
	7" HD
	800*R.G.B.*480
	Yes
	IP54
	500:1
	450cd/m ²
	-20°C ~ 70°C -68°F ~ 158°F
	10G
	12/24V

Monitor Menu



PICTURE

BRIGHT	50
CONTRAST	50
COLOR	50
RESET	

1) Picture:

M → → M → BRIGHT or CONTRAST or COLOR
 or RESET → - or +

VOLUME

VOLUME	50
--------	----

2) Volume:

M → + → → M → VOLUME

OPTION

LANG	ENGLISH
ROTATE	
ZOOM	16:9
V1V2-3S	OFF
BC2-AV1	OFF
AUTO DIM	ON

3) Option:

M → + → → M → LANG or ROTATE or ZOOM or V1V2-3S or BC2-V1 or AUTO DIM
 → - or +

SYSTEM

S-COLOR	AUTO
GUIDE LINES	OFF
ACC1-TIME	00SEC
ACC2-TIME	00SEC
ACC3-TIME	00SEC
ACC4-TIME	00SEC

4) System:

M → + → → M → S-COLOR or GUIDE LINES or ACC1-TIME or ACC2-TIME or ACC3-TIME or ACC4-TIME
 → - or +

CLOCK

SLEEP	0
-------	---

5) Clock:

M → + → → M → SLEEP → - or +

Applications

